

Charlton® WOODWORKER

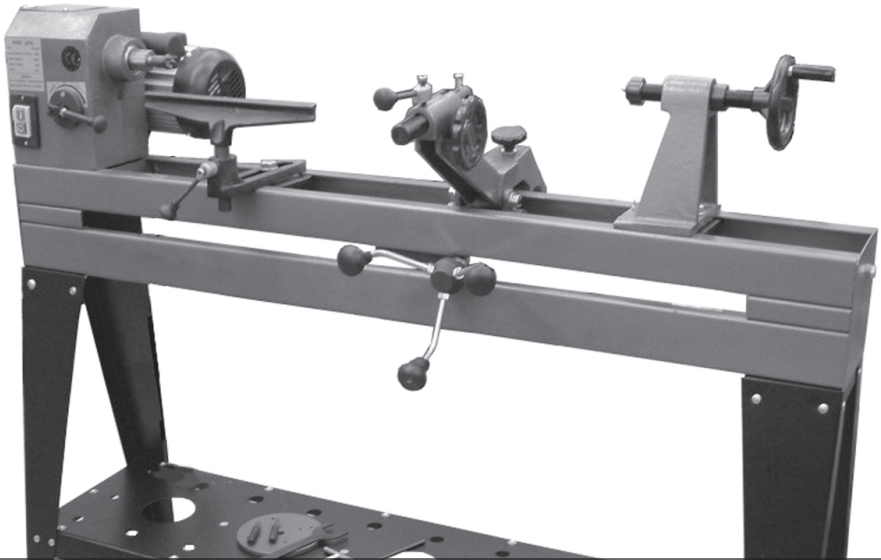

40" (1000mm) WOOD LATHE WITH COPY FUNCTION

Model No CWL1000CF

Part No 6501670

OPERATING & MAINTENANCE INSTRUCTIONS



GC0710

INTRODUCTION

Thank you for purchasing this CLARKE Wood Lathe.

Before attempting to operate the machine, it is essential that you read this manual thoroughly and carefully follow all instructions given. In doing so you will ensure the safety of yourself and that of others around you, and you can also look forward to the product giving you long and satisfactory service.

GUARANTEE

This CLARKE product is guaranteed against faulty manufacture for a period of 12 months from the date of purchase. Please keep your receipt as proof of purchase.

This guarantee is invalid if the product is found to have been abused or tampered with in any way, or not used for the purpose for which it was intended.

Faulty goods should be returned to their place of purchase, no product can be returned to us without prior permission.

This guarantee does not effect your statutory rights.

ENVIRONMENTAL PROTECTION



Do not dispose of this product with general household waste. All tools, accessories and packaging should be sorted, taken to a recycling centre and disposed of according to the laws governing Waste Electrical and Electronic Equipment.

PARTS & SERVICING

For parts & servicing, please contact your nearest dealer, or CLARKE International, on one of the following numbers.

PARTS & SERVICE TEL: 020 8988 7400

PARTS & SERVICE FAX: 020 8558 3622

or e-mail as follows:

PARTS: Parts@clarkeinternational.com

SERVICE: Service@clarkeinternational.com

CONTENTS

Introduction	2
Guarantee	2
Environmental Protection	2
Parts & Service Contacts	2
General Safety Rules	4
Electrical Connections	7
Main Components	8
Unpacking & Assembly	9
Operation	13
Maintenance	15
Troubleshooting	16
Technical Specification	17
Parts List and Diagrams	18
Accessories	22
Declaration of Conformity	23

SAFETY SYMBOLS

The following safety symbols are displayed on the machine.



Wear dust protection



Wear eye protection



Read instructions before use

GENERAL SAFETY RULES

Important Note: Although the operation manual contains extensive instruction on safe working with power tools, every power tool involves a certain residual risk which cannot be completely excluded. Power tools must therefore always be operated with caution.

WORK AREA SAFETY

1. *Keep work area clean and well lit.* Cluttered or dark areas invite accidents.
2. *Do not operate power tools in explosive atmospheres, such as in the presence of flammable liquids, gases or dust.* Power tools create sparks which may ignite the dust or fumes.
3. *Keep children and bystanders away while operating a power tool.* Distractions can cause you to lose control.

ELECTRICAL SAFETY

1. *Power tool plugs must match the outlet. Never modify the plug in any way. Do not use any adapter plugs with earthed (grounded) power tools.* Unmodified plugs and matching outlets will reduce risk of electric shock.
2. *Avoid body contact with earthed or grounded surfaces, such as pipes, radiators, ranges and refrigerators.* There is an increased risk of electric shock if your body is earthed or grounded.
3. *Do not expose power tools to rain or wet conditions.* Water entering a power tool will increase the risk of electric shock.
4. *Do not abuse the cable. Never use the cable for pulling or unplugging the power tool. Keep cable away from heat, oil, sharp edges or moving parts.* Damaged or entangled cables increase the risk of electric shock.
5. *If operating a power tool in a damp location is unavoidable, use a residual current device (RCD) protected supply.* Use of an RCD reduces the risk of electric shock.

PERSONAL SAFETY

1. *Stay alert, watch what you are doing and use common sense when operating a power tool. Do not use a power tool while you are tired or under the influence of drugs, alcohol or medication.* A moment of inattention while operating power tools may result in serious personal injury.
2. *Use personal protective equipment. Always wear eye protection.* Protective equipment such as dust mask or non-skid safety shoes used in appropriate conditions will reduce personal injuries.
3. *Prevent unintentional starting. Ensure the switch is in the off-position*

before connecting to power source and/or battery pack, picking up or carrying the tool.

- 4. Remove any adjusting key or wrench before turning the power tool on. A wrench or a key left attached to a rotating part of the power tool may result in personal injury.*
- 5. Do not overreach. Keep proper footing and balance at all times. This enables better control of the power tool in unexpected situations.*
- 6. Dress properly. Do not wear loose clothing or jewellery. Keep your hair, clothing and gloves away from moving parts. Loose clothes, jewellery or long hair can be caught in moving parts.*
- 7. If devices are provided for the connection of dust extraction and collection facilities, ensure these are connected and properly used. Use of dust collection can reduce dust-related hazards.*

POWER TOOL USE AND CARE

- 1. Do not force the power tool. Use the correct power tool for your application. The correct power tool will do the job better and safer at the rate for which it was designed.*
- 2. Do not use the power tool if the switch does not turn it on and off. Any power tool that cannot be controlled with the switch is dangerous and must be repaired.*
- 3. Disconnect the plug from the power source, changing accessories, or storing power tools. Such preventive safety measures reduce the risk of starting the power tool accidentally.*
- 4. Store idle power tools out of the reach of children and do not allow persons unfamiliar with the power tool or these instructions to operate the power tool. Power tools are dangerous in the hands of untrained users.*
- 5. Maintain power tools. Check for misalignment or binding of moving parts, breakage of parts and any other condition that may affect the power tool's operation. If damaged, have the power tool repaired before use. Many accidents are caused by poorly maintained power tools.*
- 6. Keep cutting tools sharp and clean. Properly maintained cutting tools with sharp cutting edges are less likely to bind and are easier to control.*
- 7. Use the power tool, accessories and tool bits etc. In accordance with these instructions, taking into account the working conditions and the work to be performed. Use of the power tool for operations different from those intended could result in a hazardous situation.*

SERVICE

- 1. Have your power tool serviced by a qualified repair person using only identical replacement parts. This will ensure that the safety of the power tool is maintained.*

ADDITIONAL SAFETY RULES FOR WOODLATHES

1. **IMPORTANT:** You should not operate this machine unless you are thoroughly familiar with woodlathes and turning techniques. If there is any doubt whatsoever you should consult a qualified person.
2. **ALWAYS** store chisels safely when you have finished with the machine.
3. **CAUTION:** This machine is designed for use with wood lathe chisels only.
4. **NEVER** attempt to turn a workpiece unless a suitable support is used.
5. **ALWAYS** stop the lathe before removing workpieces, work supports or swarf from the table.
6. **ALWAYS** be sure that the workpiece is securely locked in position.
7. **ALWAYS** keep hands and fingers away from the moving workpiece.



WARNING: DUST GENERATED FROM CERTAIN MATERIALS CAN BE HAZARDOUS TO YOUR HEALTH. ALWAYS OPERATE THE LATHE IN A WELL VENTILATED AREA. USE A DUST COLLECTION SYSTEM WHENEVER POSSIBLE.

ELECTRICAL CONNECTIONS



WARNING! Read these electrical safety instructions thoroughly before connecting the product to the mains supply.

Before switching the product on, make sure that the voltage of your electricity supply is the same as that indicated on the rating plate. This product is designed to operate on 230VAC 50Hz. Connecting it to any other power source may cause damage.

This product may be fitted with a non-rewireable plug. If it is necessary to change the fuse in the plug, the fuse cover must be refitted. If the fuse cover becomes lost or damaged, the plug must not be used until a suitable replacement is obtained.

If the plug has to be changed because it is not suitable for your socket, or due to damage, it should be cut off and a replacement fitted, following the wiring instructions shown below. The old plug must be disposed of safely, as insertion into a mains socket could cause an electrical hazard.



WARNING! The wires in the power cable of this product are coloured in accordance with the following code:

Blue = Neutral Brown = Live Yellow and Green = Earth

If the colours of the wires in the power cable of this product do not correspond with the terminal markings of your plug, proceed as follows.

- **The wire which is coloured Blue must be connected to the terminal which is marked N or coloured Black.**
- **The wire which is coloured Brown must be connected to the terminal which is marked L or coloured Red.**
- **The wire which is coloured Yellow and Green must be connected to the terminal which is marked E or  or coloured Green.**

Plug must be BS1363/A approved

Earth
(Green and Yellow)

Neutral
(Blue)

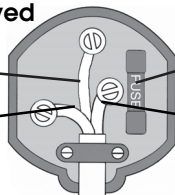

Always fit a 13 Amp fuse.

Live
(Brown)

Ensure that the outer sheath of the cable is firmly held by the clamp

We strongly recommend that this machine is connected to the mains supply via a Residual Current Device (RCD).

If in doubt, consult a qualified electrician. DO NOT attempt repairs yourself.

MAIN COMPONENTS

- | | | | |
|---|--------------------------|---|-----------------------------|
| A | ON/OFF Switch | J | Tail-stock Body |
| B | Speed Control | K | Tail-stock Advancing Handle |
| C | Headstock Centre Spur | L | Tool Rest Support |
| D | Tool Rest | M | Faceplate |
| E | Tool Rest Locking Lever | N | Open Wrench |
| F | Tool Holder | O | T-Spanner |
| G | Copy Tension Adjuster | P | Drift Rod |
| H | Copy Follower | Q | Cutting Tool(s) |
| I | Tail-stock Spur Assembly | R | Leadscrew Handles |

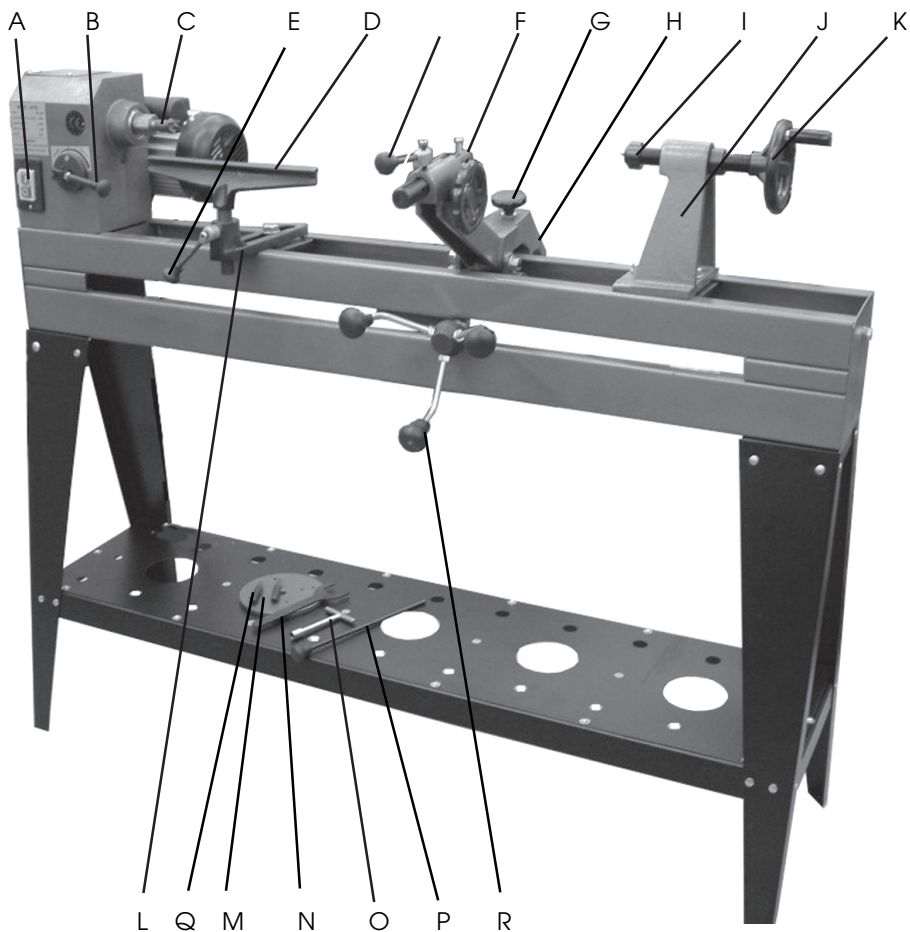

UNPACKING & ASSEMBLY

When unpacking, check for damage or omissions etc. Any found should be reported to your CLARKE dealer where the lathe was originally purchased. Do not discard the packaging until the lathe is assembled.



WARNING: DUE TO THE WEIGHT OF THE LATHE BED ASSEMBLY, IT IS ESSENTIAL THAT TWO PEOPLE PERFORM THE UNPACKING, ASSEMBLY AND POSITIONING.

The numbers in the following assembly instructions refer to the parts lists and diagrams on pages 18-22.

The following items are supplied loose:

1 x Lathe c/w Tailstock & Tool Carrier	1 x Open Wrench
1 x Tool Rest	1 x Eye Shield Assembly
1 x Tool Rest Holder	1 x 10mm T-Wrench
1 x Face Plate	2 x Hex Keys (S3 & S4)
1 x Headstock Centre Spur	1 x Drift Rod
1 x Tailstock Spur Assembly	2 x Cutting Tools
1 x Copy Follower Assembly	3 x Wood Chisels
1 x Tool Holder Locking Handle	1 x Fixings Pack
3 x Leadscrew Handles	2 x Stand Front Legs
	2 x Stand Rear Legs
	2 x Stand Long Supports
	2 x Stand Short Supports
	2 x Stand Top Plates
	1 x Stand Shelf Plate
	1 x Instruction Manual (this document)

ASSEMBLY OF THE STAND

1. Assemble the front & rear legs, supports and top plates using the coachbolts, nuts and washers as shown in Fig 1.
2. Assemble the stand loosely before tightening all the fixings together.
3. With the help of an assistant, position the lathe over the top plates and align the holes in the lathe bed with the holes in the stand top plate. Secure with the bolts supplied and tighten them evenly.



ASSEMBLY OF FACEPLATE, TAILSTOCK & LEADSCREW

1. If faceplate turning is required, screw the faceplate (24) onto the headstock spindle (42) while using the open wrench provided to prevent the spindle from turning. Tighten the faceplate as shown in Fig 2.
2. If spur turning is required, insert the headstock spur (25) into the tapered hole in the headstock spindle as shown in Fig 3a.

The spur can later easily be removed by driving it away from the headstock using the drift rod provided.

3. Insert the tail-stock spindle assembly (43/44/45) into the tail-stock as shown in Fig 3b, the taper of the shaft gripping it in place.

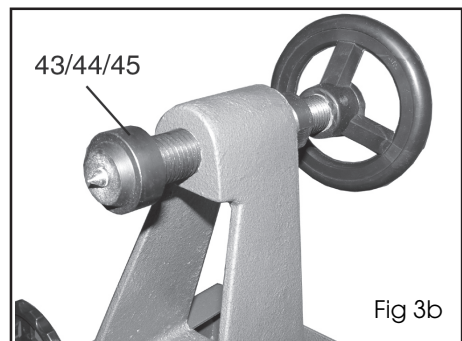
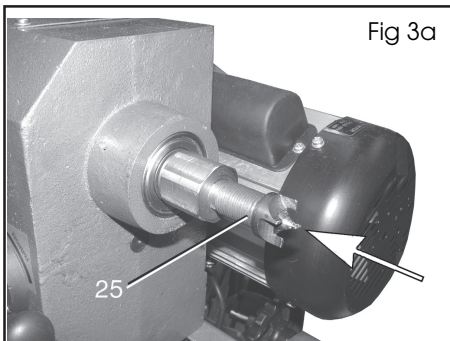
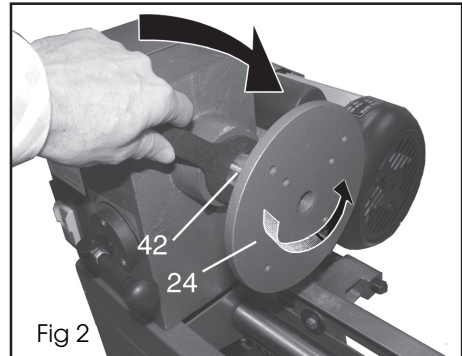

4. Fit the leadscrew hub (79) onto the leadscrew axle (78) and secure with a grub-screw (50).
If not already fitted, screw the leadscrew handles (113) into the leadscrew hub (79) and tighten by hand as much as possible.

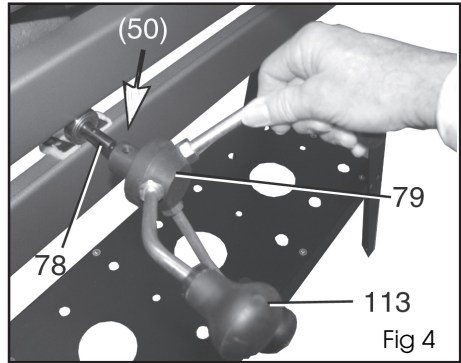

Fig 4

ASSEMBLY OF THE COPY FOLLOWER

If the copy system is to be used proceed as follows;

1. Position the copy follower body (53) over the lead screw 3-way trunnion (77) and connect it using the copy pivot stud (73) and tighten the nuts on each side as shown in Fig 5.
2. Connect the copy tension spring (68) to the locating hole in the spring attachment plate (55).
3. Pass the slot-headed bolt (67) through the other end of the spring before screwing it into the tip of the leadscrew axle (78) as shown in Fig 6.

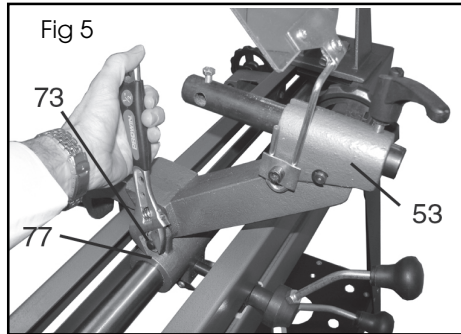

Fig 5

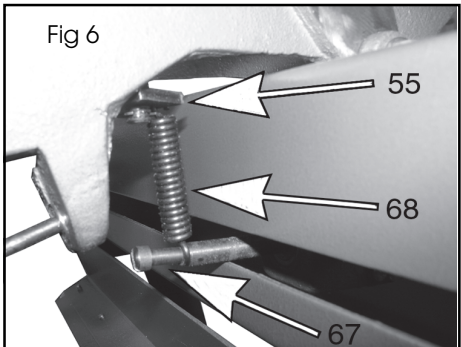
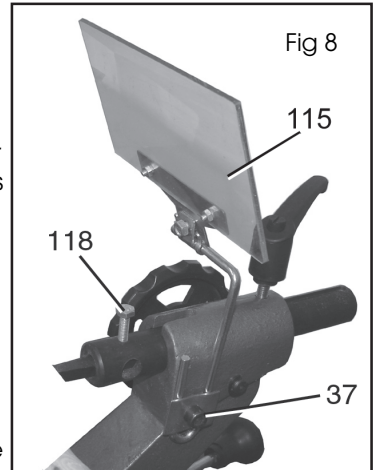
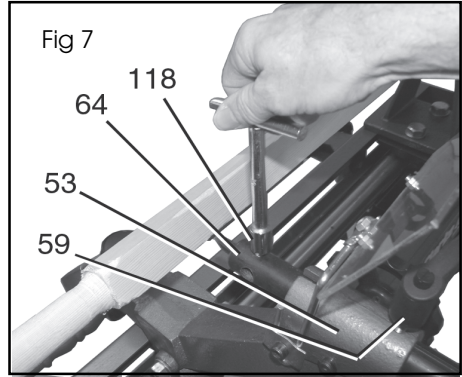

Fig 6

ASSEMBLING THE COPY TOOL

1. Install the copy toolholder rack (64) into the hole in the copy follower body (53) and drive it through using the handwheel (1) and the pinion gear (71) inside the copy follower body.
2. Insert your chosen cutting tool into the tool holder and tighten the retaining bolt (118) using the T-wrench as shown in Fig 7.
3. Advance the tool to the workpiece and secure with the locking handle (59). The tool tip should be at the same height as the centre axis of the lathe.
4. Fit the eyeshield (115) to the copy follower body using the socket-headed bolt (37) as shown in Fig 8.



ASSEMBLING THE HAND CHISEL REST

If the copy system is not being used, the standard tool rest for hand chisels can be used as follows:

1. Set the chisel rest holder (101) on the lathe bed and secure in position with the securing plate (108) and the bolt/washer (94/95) as shown in Fig 9.
2. Position the working edge of the rest (100) level with the centre axis of the lathe and secure with the locking lever.
3. Position the rest level slightly above the lathe centreline and approx 3mm from the workpiece and tighten the locking handle (59) to secure. The rest can be used parallel with the workpiece or at 90 degrees for faceplate turning.

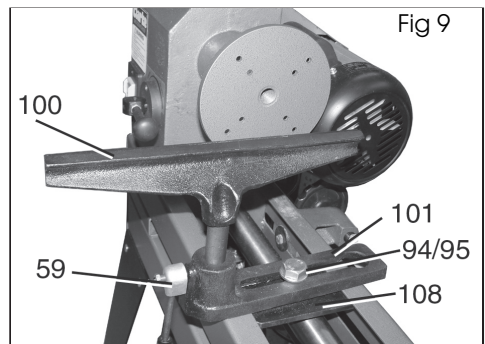

OPERATION

1. Ensure the cutting tool, tool rests and tailstock are securely locked in position before starting work.
2. Always rotate the workpiece by hand and check it does not strike the tool/tool rest before switching on the motor.
3. To turn the lathe ON, press the green push-button. Press the red button to stop.
4. Avoid turning timber which has splits or substantial knots or voids and take special care if these are discovered.
5. Always use the lowest speed when starting a new workpiece.
6. When turning, always roughly turn the work to a cylinder at low speed.
7. Take care that the turning tools do not bite suddenly into the workpiece.
8. Always position the toolrest just above the centreline of the lathe.

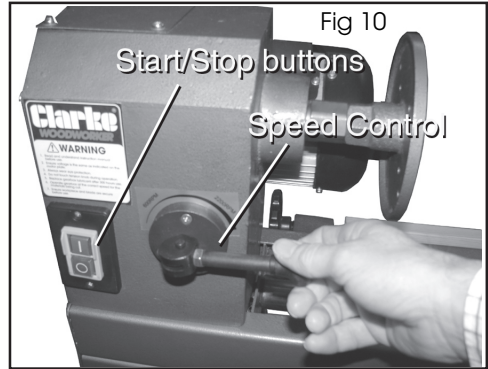

SPEED CONTROL

1. Set the speed using the speed control lever as shown in Fig 10. Always set the lever to the lowest setting before switching the machine on or off. The following settings serve as an approximate guide.

SPINDLE TURNING		
SQUARE	ROUGHING	FINISHING
1"	1700	2200
2"	1200	2200
3"	700	2200
4"	600	2200
FACE PLATE TURNING		
DIAMETER	ROUGHING	FINISHING
6"	1700	2200
8"	700	2200
9"	600	2200

COPY TURNING

1. Take the template object which is to be copied and mark diagonal lines on each end in order to show the centre point before installing it in the copy stock position. Pierce the template with the copy spindle spur (8) and then tighten both ends equally to hold the template as shown in Fig 11.
2. Set the new workpiece in the lathe by marking the centre point as above and securing in position between the head and tailstock as shown in Fig 12.
3. Begin turning by roughing off the workpiece until it is cylindrical and ready for fine turning.
4. Check that the copy follower is resting on the template object and will follow the outline profile as the assembly is moved along as shown in Fig 13.
5. Set the tool post such that the cutting tool is just level with the axis of the lathe and workpiece and begin turning progressively from one end, advancing the tool steadily. Take small cuts to assess the progress and check that the copy follower runs smoothly.
6. Progress slowly to ensure the copy follower roller/pin remains in contact with the template object at all times. Take care that the follower does not bounce on sudden shape changes.

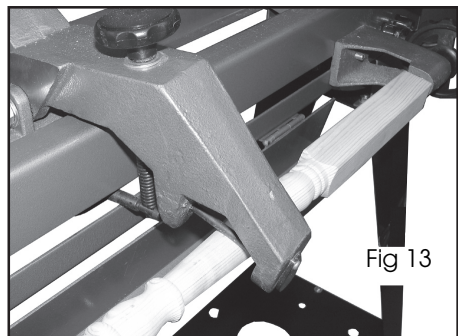
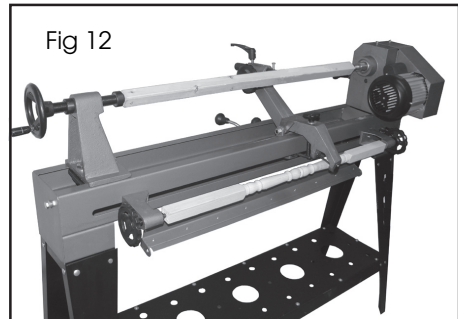
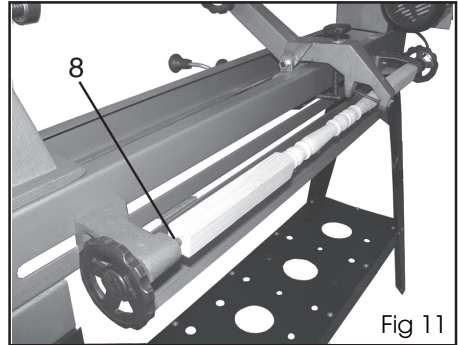

Different tools may be used according to the desired shape of the workpiece; e.g. round-nosed, square-nosed, spear point, etc. These may need changing during the operation.

MAINTENANCE

It is essential that the machine is properly maintained. Always inspect before use. Any damage should be repaired and faults rectified. The machine requires very little maintenance other than the following guidelines.

IMPORTANT - Disconnect from mains power before cleaning.

1. Vacuum clean any dust or shavings that accumulate in or on the motor.
 2. Check all cables periodically for security, and that they are in good condition and not cracked.
 3. Check tightness of mounting bolts.
 4. Check drive belt for wear and replace if frayed or otherwise damaged.
 5. Periodically lubricate the tail-stock, copy stock and tool carrier screw threads with engine oil such as SAE30 grade if they become stiff to use.
 6. Lightly lubricate the tail-stock and tool-post locking handles with oil if they become difficult to use.
- The ball bearings in the headstock and tail-stock spindles and in the copy live roller pin are greased and permanently sealed at the factory and require no further lubrication.

REPLACING THE BELT

1. Undo the retaining screws and remove the belt guard.
2. By pushing the speed control lever, expand the two halves of the driven pulley (31) allowing the belt to adopt its smallest diameter at this end.
3. Rotate the motor pulley (18/19) to dismount the drive belt from it and then lift it off the driven pulley.
4. Replacement is a reverse of the removal procedure. A broad-bladed screwdriver or similar will be useful to prize the two halves of the motor pulley apart against the pressure of the spring (17). Ensure the left & right halves of the drive pulley spring back to grip the belt and that the belt is in tension.

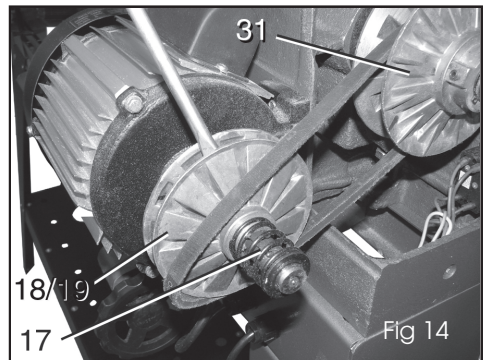

In case of problems refer to TROUBLESHOOTING on page 16. If you are unable to rectify any faults, please contact your local dealer or Clarke International Service Department on 0208 988 7400 for assistance.

TROUBLESHOOTING

PROBLEM	CAUSES	SUGGESTIONS
Motor will not run.	1. Defective/broken switch.	Replace or return to your Clarke dealer for repair.
	2. Damaged power cable.	Replace cable or return to your Clarke dealer for repair.
	3. Open circuit, loose connections or burned out motor.	Return to your Clarke dealer for repair. Attempting to repair the motor may be hazardous unless carried out by a qualified technician.
	4. Blown fuse or circuit breaker	Replace fuse or re-set circuit breaker. Turn off other machines on the same circuit.
	5. Low voltage	Check the power supply for correct voltage. Use another circuit or have a qualified electrician upgrade the power supply.
Motor will not start and fuses or circuit breaker trip out.	1. Short circuit in motor or power cable.	Return to your Clarke dealer for repair.
	2. Incorrect fuses or circuit breakers.	Replace with correct fuse or circuit breaker for the circuit.
Motor fails to reach full power.	1. Overloaded circuit.	Turn off other machines & retry.
	2. Unsuitable extension cable.	Replace with correct size extension cable (rated at <math><0.75\text{mm}^2</math> section).
Motor stalls.	1. Short circuit in motor.	Return to your Clarke dealer for repair. Attempting to repairing the motor may be hazardous unless carried out by a qualified technician.
	2. Incorrect fuses or circuit breakers.	Replace with correct fuse or circuit breaker for the circuit.
	3. Overloaded circuit.	Turn off other machines & retry.
	4. Low voltage.	Check the power supply for correct voltage. Use another circuit or have a qualified electrician upgrade the service.
Noisy operation	1. Incorrect belt tension.	Adjust belt tension. See "Replacing the Belt" section on page 15.
	2. Worn bearings.	Overhaul or return to your Clarke dealer for repair.
Tailstock loose on bed	Locking handle not tight.	Tighten locking handle
Wood burns at tailstock end	Tailstock set too tight. Lack of lubrication.	Ease off tailstock adjustment and lubricate tailstock spur.

TECHNICAL SPECIFICATION

Feature	Specification
Weight	69 kg
Dimensions (L x W x H)	1440 x 455 x 1180 mm
Speed	600 - 2200 rpm (variable)
Distance between centres	1000 mm
Height of centreline from base frame	173 mm
Turning Capacity	350 mm
Headstock Thread	3/4" UNF
Headstock Taper	MT1
Tailstock Taper	MT2
Motor Operating Voltage/Frequency	230V 50Hz
Rated Input Wattage	550 W
Motor Output	370 W
Sound Pressure Level LpA	No load 72.9 / Loaded 79 dB(A)
Measured Sound Power Level LwA	No load 85.9 / Loaded 92 dB(A)
Uncertainty K	3.0 dB(A)

Please note that the details and specifications contained herein, are correct at the time of going to print. However, CLARKE International reserve the right to change specifications at any time without prior notice.

PARTS LIST

No	Description
1	Hand Wheel
2	Grub Screw M6 x 10
3	Support Arm
4	Washer 8 mm diameter
5	Machine Screw M6 x 8
6	Folded Plate
7	Movable Plate
8	Copy Spindle M18
9	Bolt M6 x 8
10	Hinge
11	S/t Screw M4 x 8
12	Spindle Cover Plate
13	Grub Screw M5 x 8 mm
14	Power Cable
15	Circlip 22mm
16	Penny Washer
17	Coil Spring
18	Motor Pulley (Left)
19	Motor Pulley (Right)
20	Washer 5 mm dia
21	Parallel Key
22	Motor
23	Headstock Body
24	Face Plate
25	Spur Centre
26	Circlip 24 dia
27	Pulley Spindle (right)
28	Drive Belt 560 mm circumference
29	Pulley Spindle (left)
30	Circlip 55 dia
31	Bearing B0106

No	Description
32	Speed Shift Lever
33	Coil Spring
34	Nut M8
35	Bolt M8 x 25 mm
36	Speed Control Shaft
37	Socket head Bolt M8 x 20
38	Circlip
39	Bearing 80205
40	Circlip 52 mm diameter
41	Spindle Key
42	Headstock Spindle
43	Tailstock Spur
44	Bearing 80201
45	Taper Shank
46	Tailstock Body
47	Tailstock Spindle
48	Locking Nut M18
49	Tailstock Handwheel
50	Grubscrew M8 x 8
51	Bearing 80025
52	Living Roller Arm Pin
53	Copy Follower Body
54	Copy Tension Screw
55	Spring Attachment Plate
56	Grubscrew M6 x 5 mm
57	Tool Carrier Pinion
58	Cover Tab
59	Locking Handle Arm
60	Wear Block
61	Screwed Shank
62	Screw

PARTS DIAGRAM

When requesting spare parts, please quote the reference DDCWL1000 followed by the number (1-118) on the following parts lists.

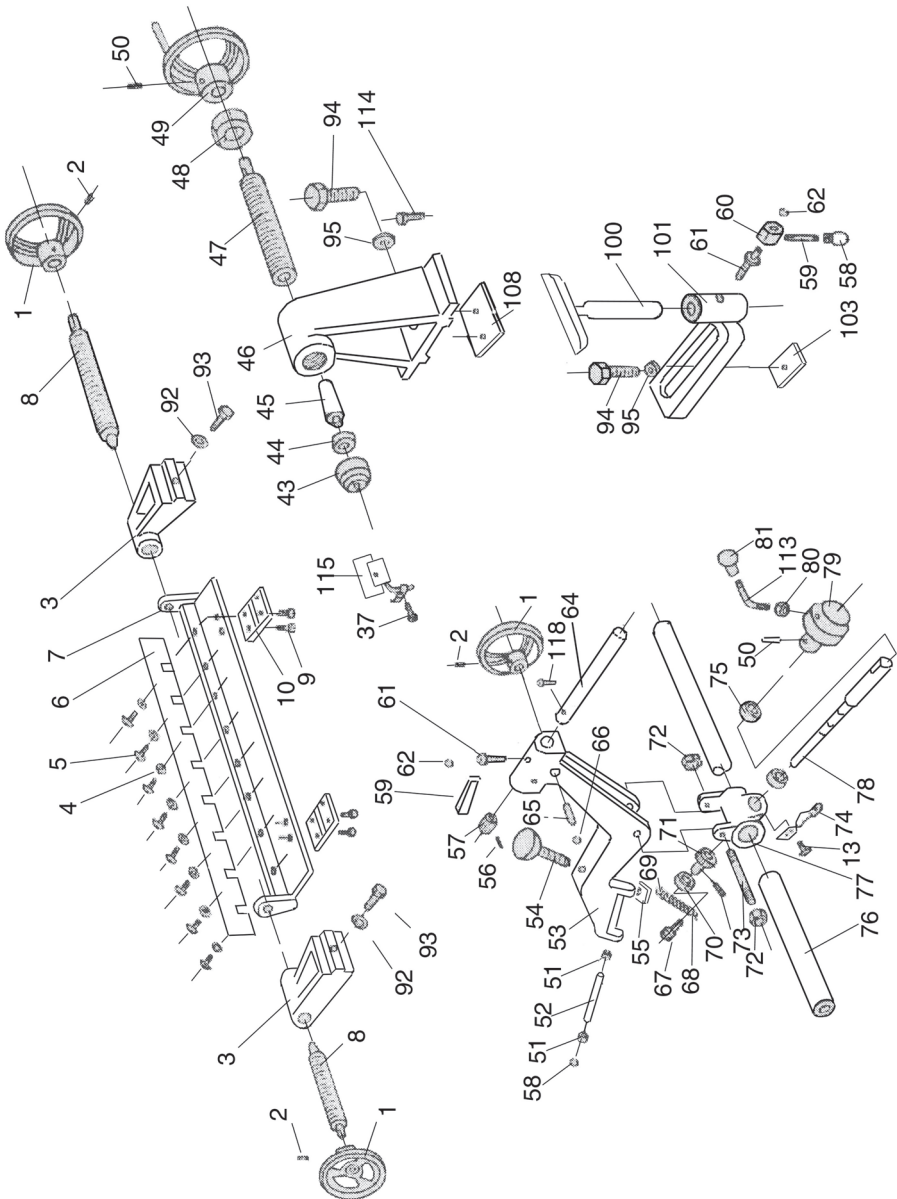

PARTS LIST

No	Description
63	Bolt M6 x 25 mm
64	Copy Toolholder Rack
65	Copy Toolholder Pinion
66	Circlip 8 mm dia
67	Slot Headed Bolt
68	Copy Tension Spring
69	Circlip 6 mm dia
70	Bearing 80200
71	Leadscrew Pinion
72	Nut M12
73	Copy Pivot Stud
74	Leadscrew Bearing Rest
75	Bearing 80201
76	Leadscrew Guide Rack
77	3-way Trunnion
78	Leadscrew Axle
79	Leadscrew Hub
80	Nut M10
81	Knob
82	Cover Retaining Screw
83	ON/OFF Switch
84	Screw M8 x 12
85	Speed Control Spindle
86	Speed Label
87	Circlip
88	Speed Control Cam
89	C/sunk Screw M4x20
90	Pin
91	Speed Control Lever
92	Washer
93	Bolt M8x20

No	Description
94	Bolt M16x35
95	Washer 16 dia
96	Lathe Bed
97	Washer 10 dia
98	Bolt M10 x18
99	Stand Top Plate
100	Chisel Rest
101	Chisel Rest Holder
102	Stand Front (right)
103	Anchor Plate
104	Stand Long Support
105	Stand Front (left)
106	Stand Cross Support
107	Coachbolt M8x12
108	Securing Plate
109	Washer 8 mm dia
110	Stand Base Plate
111	Cable Gland M16x1,5
112	Belt Guard
113	Leadscrew Handle
114	Bolt M8 x 16
115	Eye Shield
116	Capacitor 10uF
117	Capacitor Cover
118	Tool Retaining Bolt
n/a	Open Spanner
n/a	Drift Rod
n/a	Hexagonal Key S3
n/a	Hexagonal Key S4
n/a	T-Wrench
n/a	User Manual

PARTS DIAGRAM

When requesting spare parts, please quote the reference DDCWL1000 followed by the number (1-118) on the accompanying parts lists.

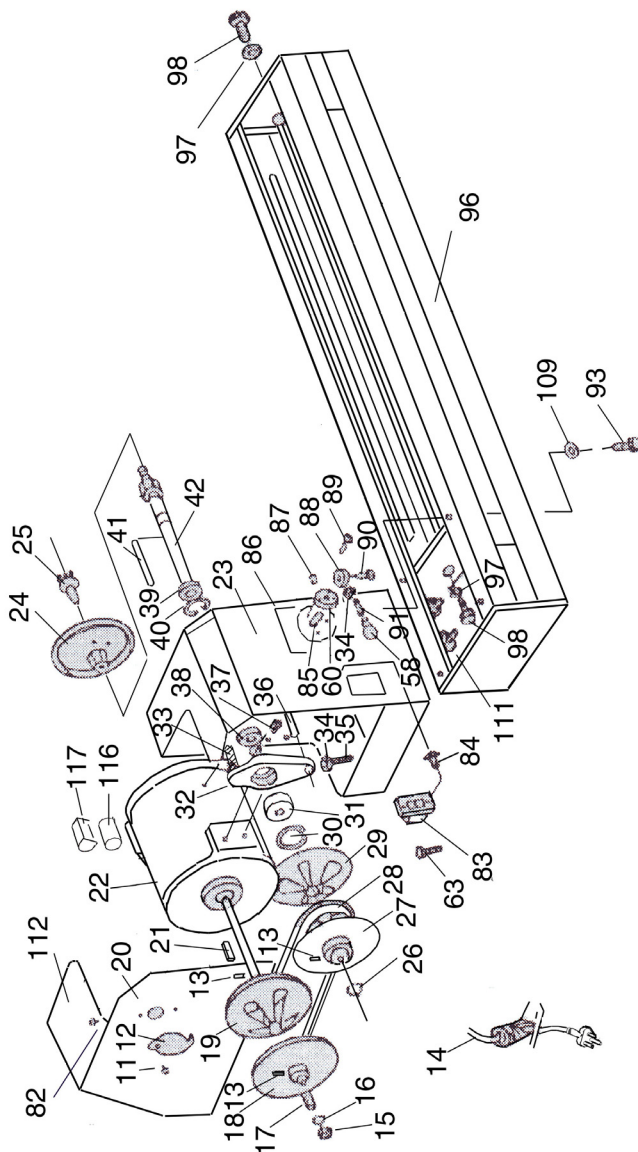

PARTS DIAGRAM

When requesting spare parts, please quote the reference DDCWL1000 followed by the number (1-118) on the following parts lists.

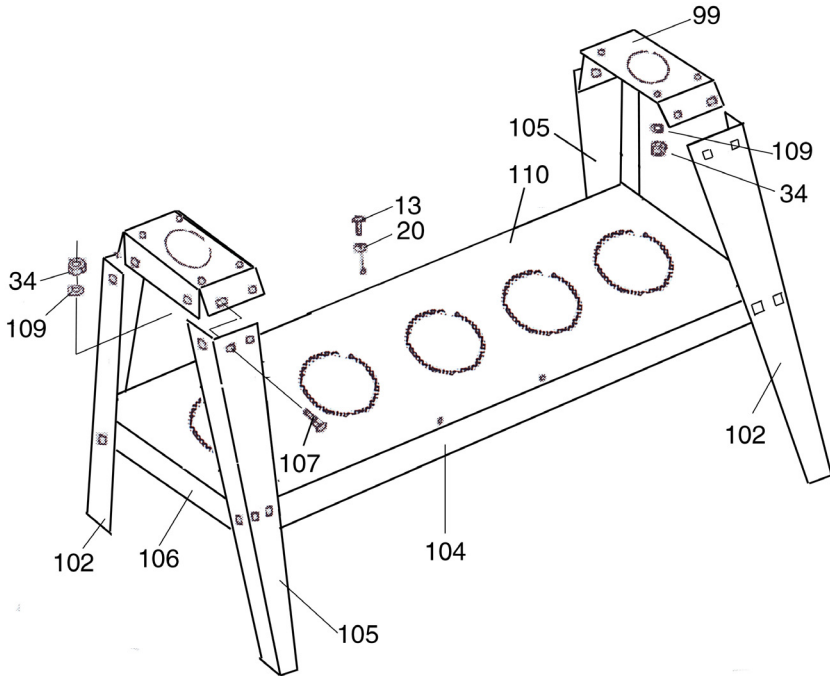

ACCESSORIES

The following range of accessories is also available from your Clarke dealer:

8-Piece Chisel Set

Part No: 6500649

4-Jaw Independent Lathe Chuck

Part No: 6500645

1/2" Cap. Tailstock Chuck

Part No: 6500643

DECLARATION OF CONFORMITY



Clarke[®]
INTERNATIONAL

Hemnall Street, Epping, Essex CM16 4LG

DECLARATION OF CONFORMITY

This is an important document and should be retained.

We hereby declare that this product(s) complies with the following directive(s):

- 2004/108/EC *Electromagnetic Compatibility Directive.*
- 2006/42/EC *Machinery Directive.*
- 2006/95/EC *Low Voltage Equipment Directive.*
- 2002/95/EC *Restriction of Hazardous substances.*

The following standards have been applied to the product(s):

- EN 55014-1:2000+A1+A2, EN 55014-2:1997+A1:2001, EN 61000-3-2:2002+A2,*
- EN 61000-3-3:1995+A1:A2:2005, EN 61029-1-2009*

The technical documentation required to demonstrate that the product(s) meet(s) the requirement(s) of the aforementioned directive(s) has been compiled and is available for inspection by the relevant enforcement authorities.

The CE mark was first applied in: 2007

Product Description: Wood Lathe (550W)
Model number(s): CWL1000CF
Serial / batch Number: N/A
Date of Issue: 02/06/2010

Signed:

.....
J.A. Clarke
Director

A SELECTION FROM THE VAST RANGE OF

Clarke®

QUALITY PRODUCTS

AIR COMPRESSORS

From DIY to industrial, Plus air tools, spray guns and accessories.

GENERATORS

Prime duty or emergency standby for business, home and leisure.

POWER WASHERS

Hot and cold, electric and engine driven - we have what you need

WELDERS

Mig, Arc, Tig and Spot. From DIY to auto/industrial.

METALWORKING

Drills, grinders and saws for DIY and professional use.

WOODWORKING

Saws, sanders, lathes, mortisers and dust extraction.

HYDRAULICS

Cranes, body repair kits, transmission jacks for all types of workshop use.

WATER PUMPS

Submersible, electric and engine driven for DIY, agriculture and industry.

POWER TOOLS

Angle grinders, cordless drill sets, saws and sanders.

STARTERS/CHARGERS

All sizes for car and commercial use.

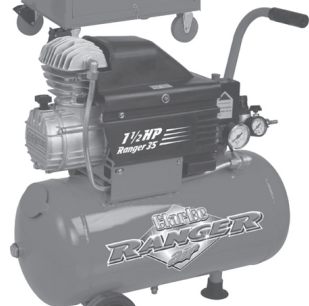

PARTS & SERVICE: 0208 988 7400

E-mail: Parts@clarkeinternational.com or Service@clarkeinternational.com

SALES: UK 01992 565333 or Export 00 44 (0)1992 565335

Clarke® INTERNATIONAL Hemnal Street, Epping, Essex CM16 4LG
www.clarkeinternational.com